

Ordering Information

This is only for reference, the actual product does not support all combinations. For selecting the specified model, follow the Autonics website.

LSC - C ① C T3 - ET

① Detection distance

5: 5 m
10: 10 m
25: 25 m

Product Components

- Product
- M3 × 8 mm bolt (SUS) × 4
- Instruction manual
- Connector cap × 1

Software

Download the installation file and the manuals from the Autonics website. Supported devices are different for each software version.

■ atLiDAR (V2.0 or later)

atLiDAR is the management program for laser scanner parameter settings, status information and monitoring data, etc.

This program communicates with the laser scanner via Ethernet communication.

2D 270° Laser Scanners



LSC Series CATALOG

For your safety, read and follow the considerations written in the instruction manual, other manuals and Autonics website.

The specifications, dimensions, etc. are subject to change without notice for product improvement. Some models may be discontinued without notice.

Major Features

- Wide detection range up to 270°, 25 m
- Supports flexible field configuration with a total of 16 field sets (1 set: 3 fields)
- Accurate and stable object detection by supporting various filter functions
- Small size (L 60 × W 60 × H 86 mm) suitable for various installation environments
- Supports Ethernet communication
- Supports atLiDAR dedicated software
- ROS, API supported
- Sold separately
 - Ethernet cable (C18-2R-A, C18-5R-A, C18-10R-A, C48-2R-A, C48-5R-A, C48-10R-A)
 - Power I/O cable (CID-2-VG, CID-5-VG, CID-10-VG, CLD-2-VG, CLD-5-VG, CLD-10-VG)

Specifications

Model	LSC-C5CT3-ET	LSC-C10CT3-ET	LSC-C25CT3-ET
Environment of use	Indoor		
Emitting property	Infrared laser		
Laser class	CLASS 1		
Wave length band	905 nm		
Max. pulse output power	6 W		
Beam conversion angle	9.5 mrad		
Scanning frequency	15 Hz		
Response time	Typ. 67 ms		
Detection distance range	0.05 to 5 m	0.05 to 10 m	0.05 to 25 m
Max. detection distance of 10 % reflector	5 m	8 m	
Detection distance error	System error: Typ. ± 60 mm, statistical error: Typ. 20 mm (1σ)		
Min. object size ⁽⁰¹⁾	At detection distance of 8 m: ≈ 121 mm		
Angular resolution	0.33°		
Aperture angle	270°		
Object reflectivity	> 4 %		
Number of field sets	16 (1 set: Consists of subfields 1, 2, 3)		
Number of field sets that can be used concurrently	1		
Unit weight (package)	≈ 228 g (314 g)		
Approval	CE, RoHS		

01) Even objects smaller than the set min. object size can be detected depending on the environment.

Power supply	9 - 28 VDC≐
Power consumption ⁽⁰¹⁾	< 4 W
Input	4 Photocoupler inputs - H: ≥ 9 - 28 VDC≐, L: ≤ 3 VDC≐
Output signal	NPN-PNP open collector output setting (software)
Load voltage	9 - 28 VDC≐
Load current	≤ 100 mA
Residual voltage	≤ 3.0 VDC≐
Insulation resistance	≥ 5 MΩ (500 VDC≐ megger)
Dielectric strength	500 VAC~ 50 / 60 Hz for 1 minute
Vibration	10 sweep cycles in each X, Y, Z axes at sine wave, 10 to 500 Hz, acceleration 5 G
Vibration (malfunction)	10 minutes in each X, Y, Z axes at sine wave, 10 to 500 Hz, acceleration 5 G
Vibration (irregular)	5 hours in each X, Y, Z axes at 5 to 250 Hz, 42.4 m/s ² RMS
Shock	3 times in each X, Y, Z axes at sine half wave, acceleration 50 G, duration 11 ms
	1000 times in each X, Y, Z axes at sine half wave, acceleration 25 G, duration 6 ms
	5000 times in each X, Y, Z axes at sine half wave, acceleration 50 G, duration 3 ms
Shock (malfunction)	6 times in each X, Y, Z axes at sine half wave, acceleration 50 G, duration 11 ms
Ambient illuminance	≤ 80,000 lx
Ambient temperature	-10 to 50 °C, storage: -30 to 70 °C (no freezing or condensation)
Ambient humidity	0 to 95 %RH, storage: 0 to 95 %RH (no freezing or condensation)
Protection structure	IP67 (IEC standard)
Connector specification	Power I / O: M12 12-pin, Ethernet: M12 8-pin
Material	Case: AL, Window: PC

01) Excluding power supplied to the load

Communication Interface

Ethernet

Communication protocol	TCP/IP
Communication speed	100BASE-TX
Baud rate	100 Mbps

Dimensions

• Unit: mm, For the detailed drawings, follow the Autonics website.

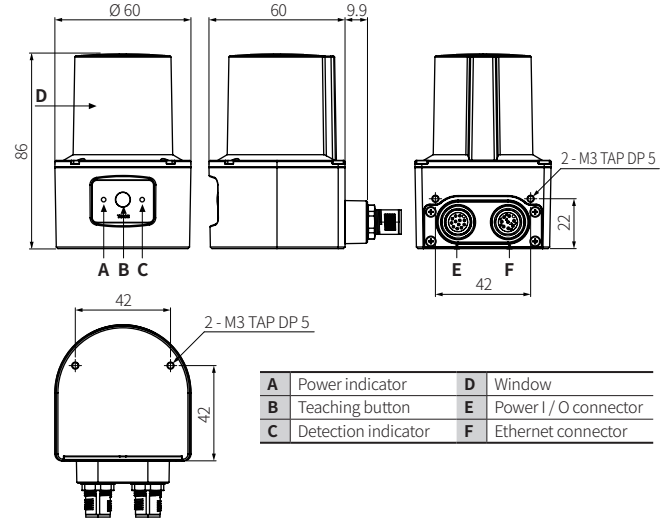

Sold Separately

- Power I / O cable: CID-□-VG, CLD-□-VG
- Ethernet cable: C18-□R-A, C48-□R-A

Sold Separately: Power I/O Cable (CID-□-VG, CLD-□-VG)

- Unit: mm, For the detailed drawings, follow the Autonics web site.
- Cable length L (m): 2 m, 5 m, 10 m

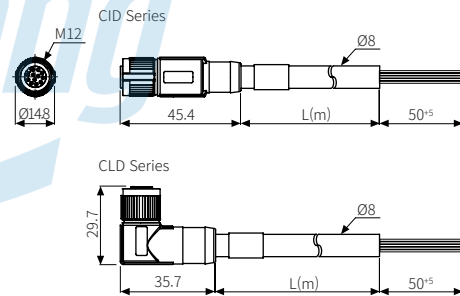

Sold Separately: Ethernet Cable (C18-□R-A, C48-□R-A)

- Unit: mm, For the detailed drawings, follow the Autonics web site.
- Cable length L (m): 2 m ± 45 mm, 5 m ± 45 mm, 10 m ± 45 mm

