

## Power REGULATOR TPR-3M

### INSTRUCTION MANUAL

Thank you for purchasing HANYOUNG product.  
Please check whether the product is the exactly same as you ordered.  
Before using the product, please read this instruction manual carefully.  
Please keep this manual where you can view at any time

**HANYOUNG NUX**

**HANYOUNGNUX CO.,LTD**

 28, Gilpa-ro 71beon-gil, Nam-gu, Incheon, Korea  
 TEL : (82-32)876-4697 FAX : (82-32)876-4696  
 http://www.hynux.com

**HEAD OFFICE**

## Safety information

Before using the product, please read the safety information thoroughly and use it properly. Alerts declared in the manual are classified to Danger, Warning and Caution by their criticality

<b>⚠ DANGER</b>	DANGER indicates an imminently hazardous situation which, if not avoided, will result in death or serious injury
<b>⚠ WARNING</b>	WARNING indicates a potentially hazardous situation which, if not avoided, could result in death or serious injury
<b>⚠ CAUTION</b>	CAUTION indicates a potentially hazardous situation which, if not avoided, may result in minor or moderate injury

### ⚠ Danger

To prevent electric shock while it is running, put to earth with the fixed screw of the unit and do not touch the radiator panel since it is very hot. Do not touch or contact the input/output terminals because they cause electric shock.

### ⚠ Warning

- Please install appropriate protective circuit on the outside if malfunction or an incorrect operation may be a cause of leading to a serious accident.
- If you use the product with methods other than specified by the manufacturer, there may be bodily injuries or property damages.
- Since this product is not designed as a safety device if it is used with systems, machines and equipment that could lead to a risk of life or property damage, please implement safety devices and protections for both lives and the applications and plan for preventing accidents.
- To prevent damage or failure of this product, please supply the rated power voltage.
- To prevent electric shock or equipment failure, please do not turn on the power until completing wiring.
- Never disassemble, modify, or repair the product. There is a possibility of malfunction, electric shock, or a risk of fire.
- Please turn off the power when mounting / dismantling of the product. This is a cause of electric shock, malfunction, or failure.

### ⚠ Caution

- Since the product operating environment influences the product performance and expected life span, please avoid using in the following places.
  - a place where humidity is high and air flow is inappropriate.
  - a place where dust or impurity accumulates, ambient temperature is high and vibration level is high.
  - a place where corrosive gas (such as harmful gas, ammonia, etc.) and flammable gas occur.
  - a place where there is direct vibration and a large physical impact to the product.
  - a place where there is water, oil, chemicals, steam, dust, salt, iron or others (Contamination class 1 or 2).
  - a place where excessive amounts of inductive interference and electrostatic and magnetic noise occur.
  - a place where heat accumulation occurs due to direct sunlight or radiant heat.
- Please do not wipe this product with organic solvents such as alcohol, benzene and others. (Please use mild detergent)
- Please make sure to inspect the product if exposed to water since there is a possibility of electric leakage or a risk of fire.
- Please connect the product and other units after turning off all the power of the product, instruments and units.
- Please make sure that the power control (TPR) is installed perpendicularly.
- Please install the product inside of the control panel and install an exhaust fan onto the top of the control panel.
- Pay attention to the edge of heat sink which is sharp.

## Suffix code

Model	Code	Information
TPR-3M	<input type="checkbox"/> <input type="checkbox"/> <input type="checkbox"/>	Slim type 3-phase power regulator
Rated current	25	25 A
	45	45 A
	55	55 A (Option)
Power supply voltage	L	100 - 240 V a.c. (Low)
Option	IS	Power isolated type

※ Option IS type is a product that can connect up to 5 in series with one temperature controller and power supply (SMPS). The general type requires a 1 to 1 connection to the temperature controller with a 24 V d.c. partial power circuit as a non-isolated type.

## Specification

Model	TPR-3M25L	TPR-3M45L
Power supply voltage	100 - 240 V a.c.	
Circuit input power	24 V d.c. 8 W	
Power frequency	50 / 60 Hz	
Rated current	25 A	45 A
Applying load	Resistive load	
Control Input	4 - 20 mA d.c. (Impedance : 100 Ω)	
Control method	Phase control (Fixed Cycle control, Variable Cycle control Option)	
Output voltage	More than 98 % of the power supply voltage (In case of maximum current input)	
Cooling method	Forced cooling (24 V d.c. FAN)	
Display method	4 LED display status and alarm status	
Insulation resistance	Min 100 MΩ (Base on 500 V d.c. mega)	
Dielectric strength	2,500 V a.c. 50 / 60 Hz for 1 min	
Line noise	Noise by noise simulator (2,000 V)	
Storage temperature	-30 ~ 90 °C	
Ambient temperature	-20 ~ 80 °C (Without Condensation)	
Ambient Humidity	45 ~ 85 % RH	
Weight	1,756 g	

## Part name and function

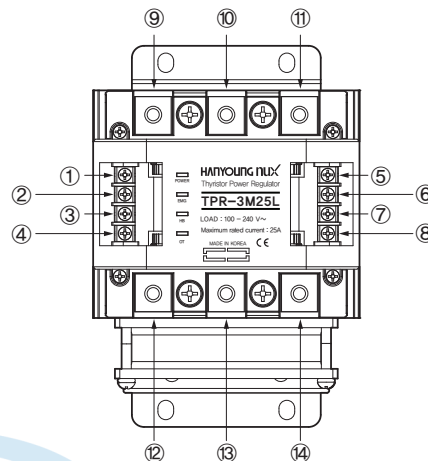

Number	Name	Description
No. 1	Control input terminal (4 - 20 mA +)	Current input terminal from temperature controller, PLC, and etc
No. 2	Control input terminal (4 - 20 mA -)	
No. 3	Circuit power supply (24 V d.c. +)	Power input for circuit drive with power supply(SMPS) and etc
No. 4	Circuit power supply (24 V d.c. -)	
No. 5	Alarm1 (Middle alarm) +	Alarm terminal to PLC, relay, etc
No. 6	Alarm1 (Middle alarm) -	
No. 7	Alarm2 (Light alarm) +	Alarm terminal to PLC, relay, etc
No. 8	Alarm2 (Light alarm) -	
No. 9	R, S, T load power input	3 Phase AC load power input
No. 10		
No. 11		
No. 12	U, V, W load terminal	3 phase load connection (Delta connection, Y connection, etc)
No. 13		
No. 14		
No. 14		

### ■ LED indicator and description

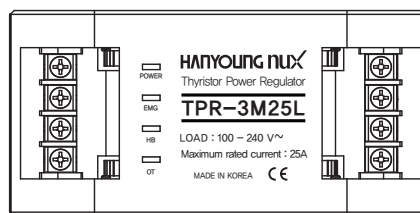

LED	Status	Alarm	Description
POWER	Flashing	When 4 - 20 mA control input is applied	
	Light on	When 24 V d.c. power is applied separately	
EMG	Flashing	Over current (Alarm2)	Over 55 A over current
	Light on	Power failure (Alarm2)	During operation (output is going out) when load power applied to TPR is cut off
HB	Flashing	Load imbalance (Alarm2)	When the deviation of the maximum and minimum values of load connected to U, V, W is more than 10 A
	Light on	SCR error (Alarm1)	When the input current is 0 % (4 mA).
OT	Flashing	Heat sink overheated 60 °C (Alarm2)	When the heat sink temperature is above 60 °C
	Light on	Heat sink overheated 80 °C (Alarm1)	When the heat sink temperature is above 80 °C

### ■ Explanation for alarm output

Alarm	TPR status	Alarm output
Alarm1	Forced shutdown (alarm output, LED display)	NPN transistor open collector output (High signal at abnormal detection)
Alarm2	Normal operation (alarm output, LED display)	

[Unit : mm]

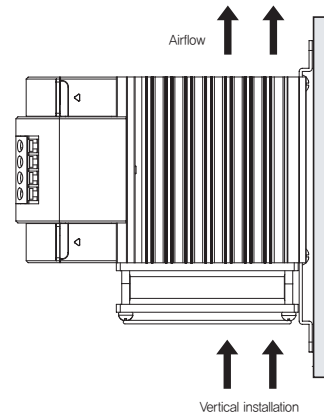
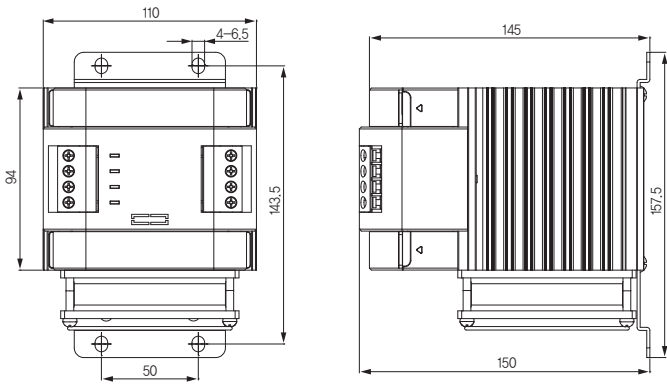

## Connection diagram

### ■ Connection diagram of load terminal

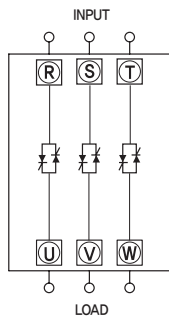

· There is no fuse inside the power regulator (TPR). It is recommended to use an external fuse separately.

· Please use a crimp terminal to tighten the terminal when tightening the terminal due to a high current flows. (Tightening terminal space of crimp terminal: 15 mm)

## Function description

### ■ Phase control

Phase control is to control the AC power supply applied to the load proportionally according to the control input signal as changing phase angle (0 ~ 180 degree) in a each half cycle, 8.33 ms.

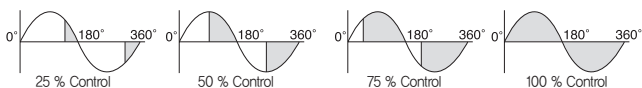

### ■ Fixed cycle control

As setting the constant cycle of the output, (1 sec), fixed cycle control is to control the AC power supply repeatedly with a constant rate of ON/OFF according to the control input.

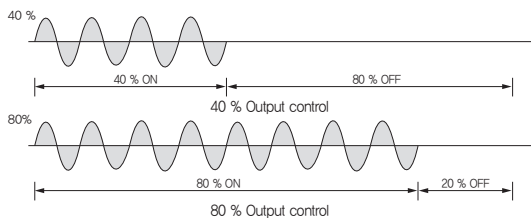

### ■ Variable cycle control

Without setting a constant cycle, variable cycle control is to control AC power supply with using the number of cycle.

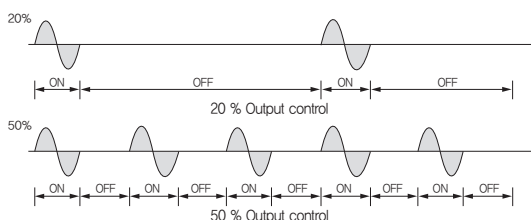

1. Please install it vertically like a picture above. If the product is installed vertically in unavoidable circumstances, please use 50 % of rated current.
2. When multiple products are closely installed, please install them with keeping a distance of more than a width of 5 cm and a length of 10 cm as as shown in the picture below.
3. In order to not block the air flow, please install the wiring duct less than the half of the heat sink height.
4. Please consider whether the air flow is good enough when installing the product. If the ambient temperature is as low as possible in the inside then the life span of the product is increasing as the durability and reliability of the product are improving. The operating ambient temperature is 0 °C ~ 40 °C. Please refer to the following graph. However, if the ambient temperature is higher than 40 °C, the maximum load current is decreasing like the below.
5. When wiring, please use crimp connectors to high current flows terminal. If the contact surface of the connectors and terminals are poor, it may lead to a fire since the wires and terminal gets overheated
6. Before applying power, this model need more than the third class grounding to prevent electric shock. This model does not have separate grounding terminal so we suggest using grounding terminal and bracket together when install this model to a panel.

