

Download manual

For detailed information on installation and commissioning, full version of the M100 manual can be downloaded at www.lsis.com

Verify & Identify the delivery

- Inspect the drive for damage. If the drive appears damaged upon receipt, contact your supplier.
- Verify receipt of the correct model by checking the information on the nameplate as shown below. If you have received the wrong model, contact your supplier.



LSLV0022M100-1EOFNS

INPUT 200-240V 1Phase 50/60Hz
10.0A

OUTPUT 0-Input V 3Phase 0.01-400Hz
3.8kVA
Ser. No 55025310146
Inspected by D. K. YU
KCC-REM-LSR-XXXXXX

| | | | | | | | | |
|--|-------------|---------------|-----------|----------|----------|----------|----------|----------|
| LSLV | 0022 | M100 | -1 | E | O | F | N | S |
| Motor capacity | | | | | | | | |
| 0001 - 0.1kW | | 0008 - 0.75kW | | | | | | |
| 0002 - 0.2kW | | 0015 - 1.5kW | | | | | | |
| 0004 - 0.4kW | | 0022 - 2.2kW | | | | | | |
| Series name | | | | | | | | |
| Input voltage | | | | | | | | |
| 1 - Single phase 200V - 240V | | | | | | | | |
| Keypad | | | | | | | | |
| E - LED keypad | | | | | | | | |
| UL type | | | | | | | | |
| O - UL open type | | | | | | | | |
| EMC filter | | | | | | | | |
| F - Built-in EMC filter[C2] | | | | | | | | |
| DC Reactor | | | | | | | | |
| N - No built-in DC reactor | | | | | | | | |
| I/O | | | | | | | | |
| S - Standard type A - Advanced type | | | | | | | | |

Mount the drive

INDUSTRIAL AUTOMATION

- Ensure that there is sufficient space to meet the clearance specifications, and that there are no obstacles impeding the cooling fan's air flow as shown below.
- When installing multiple drives into the same enclosure panel (Side-by-side installation), mount the drives with the minimum clearance of 2 mm while removing optional top covers.

| Installation space | Side-by-side installation | Mounting precaution |
|--------------------|---------------------------|---------------------|
| | | |

- Install the drive in an environment that meet the conditions such as ambient temperature (-10°C to 50°C), Humidity (95% relative humidity or free of condensation), altitude (below 1,000m) and vibration (below 1G [9.8 m/sec²])
- DIN-Rail mounting is available.

Connect drive: power

- The following figures show main circuit terminal arrangement on the drive.
- WARNING! B1, B2 terminals are for the brake resistor. Do not connect B1, B2 terminals to earth ground.
- WARNING! Power supply cables must be connected to R and T terminals.
Connecting power cables to the U, V, and W terminals will cause internal damage to the drive.

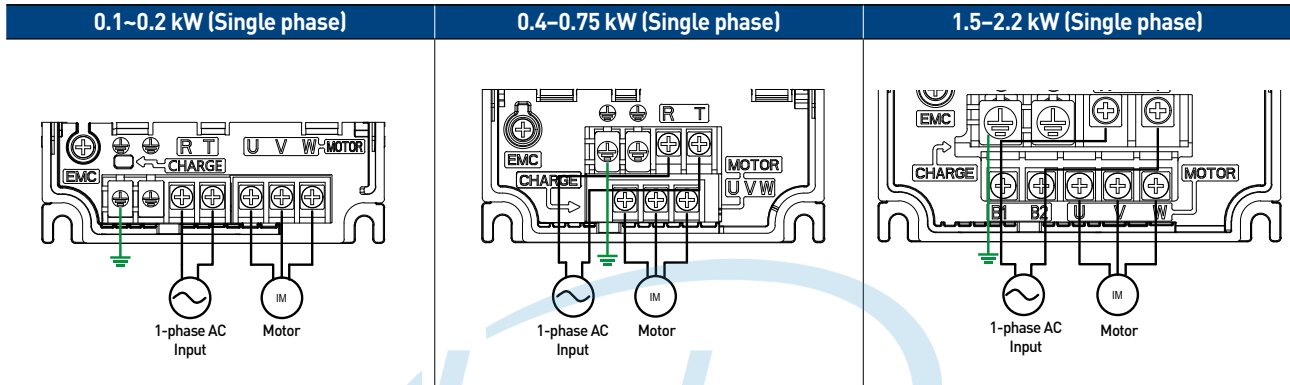

Connect drive: control

- The figures below show the control circuit terminal arrangement on the drive.
- Refer to the list of factory default value as below.

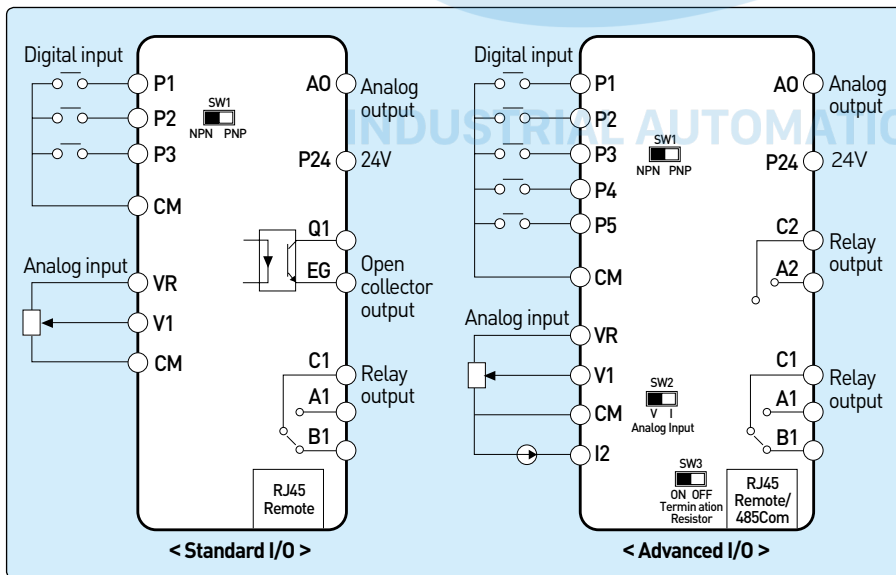

| | |
|------|---|
| SW1 | Sink/Source selection |
| SW2* | Voltage/Current selection for terminal I2 |
| SW3* | RS485 termination resistor |

| Terminal | Parameter Code | Factory Default |
|----------|----------------|-----------------|
| P1 | In-65 | Fx |
| P2 | In-66 | Rx |
| P3 | In-67 | Emergency stop |
| P4* | In-68 | RESET |
| P5* | In-69 | JOG |
| V1 | - | - |
| I2* | - | - |

| Terminal | Parameter Code | Factory Default |
|----------|----------------|------------------|
| Q1/EQ** | OU-32 | Fault |
| A1/B1/C1 | OU-31 | Fault |
| A2/C2* | OU-32 | Fault |
| A0 | OU-01 | Output frequency |

* This is available only on Advanced I/O
** This is available only on Standard I/O.

Keypad: description

| No. | Name | Description |
|-----|-------------------|---|
| ① | 7-Segment Display | Displays current operational status and parameter information. |
| ② | SET Indicator | LED flashes in parameter setting mode. |
| ③ | RUN Indicator | LED is lit during operation while flashing during acceleration or deceleration. |
| ④ | FWD Indicator | LED is lit during forward operation. |
| ⑤ | REV Indicator | LED is lit during reverse operation. |

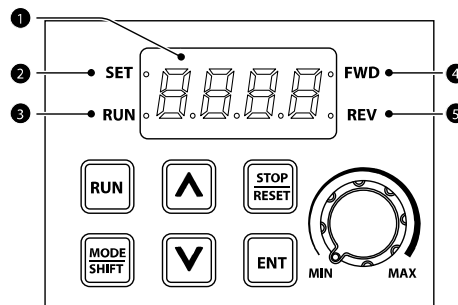

| Key | Name | Description |
|-----|------------------|---|
| | [RUN] key | Starts the drive. (Activates RUN command.) |
| | [STOP/RESET] key | STOP: Stops the drive. RESET: Resets the drive to clear fault situation. |
| | [▲] key, [▼] key | Scrolls up and down to select parameter codes, setting values, etc. |
| | [MODE/SHIFT] key | Moves the parameter groups or moves the cursor in parameter setting mode. |
| | [ENTER] key | Moves the value setting mode from the parameter selection mode. Saves the set values after adjusting the parameter values. Moves the drive status screen from the fault screen when a fault occurs. |
| | [Volume] key | Sets the output frequency. |

Set parameters and monitor the operation

Set Parameters

※ Basic Parameters in Operation Group

- Only 18 parameters are shown in the first group to run the drive basically.
- The other groups are shown when "1" is set in the parameter OGr.
- Group Selection
 - The key allows to move from one group to the next in one direction only.
- Code Selection
 - The keys allow to select the parameter code.
- Parameters value setting
 - The keys allow to adjust parameter values.
 - The set value is saved by pressing the key twice.

Monitor The Operating Status

• Output Current Monitoring

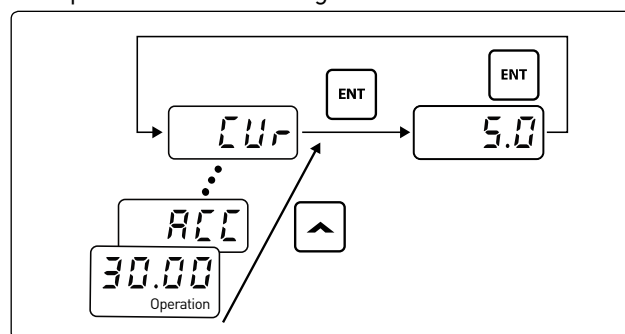

• Fault Trip Monitoring

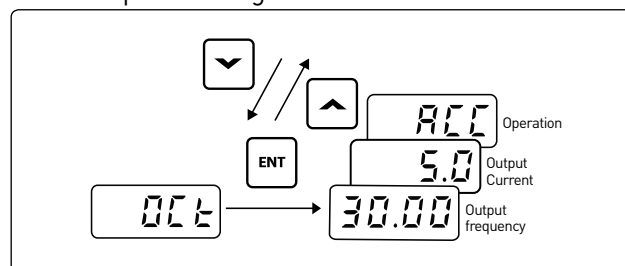

Basic set-up procedure

Motor direction inspection

- In this step the motor is checked for proper direction and operation. This test is to be performed solely from the Keypad. Apply power to the drive after all the electrical connections have been made and protective covers have been reattached.

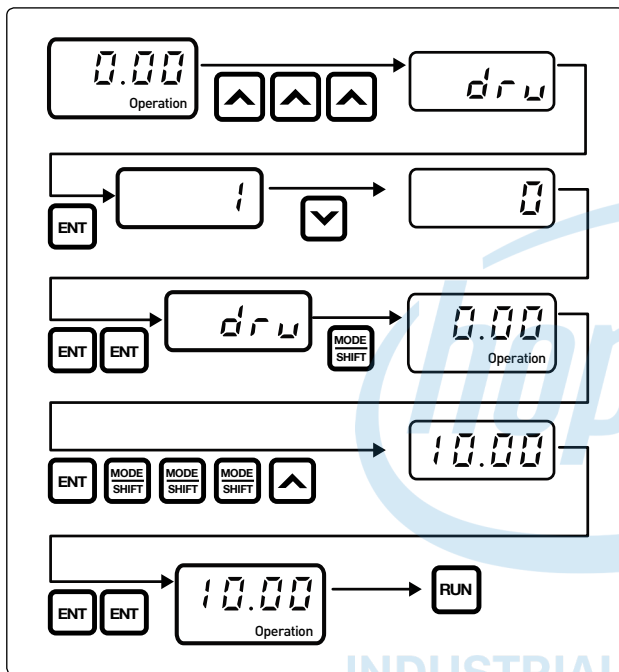

- Observe the motor's rotation from the load side and ensure that the motor rotates counterclockwise (forward).
- If the motor rotation is not correct, change the wiring of the motor. (ex. U-V-W → V-U-W)

Start/Stop and speed source settings

- This step shows how to setup the sequence and reference method of the drive. The sequence method determines how the drive receives its start and stop command and the reference method determines how the speed of the motor is controlled. Make sure all protective covers have been reattached and power is turned on.
- Select start / Stop method

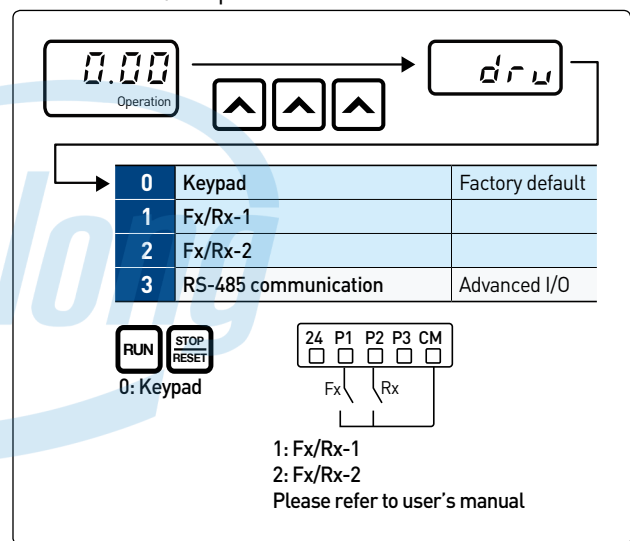

- Select frequency method

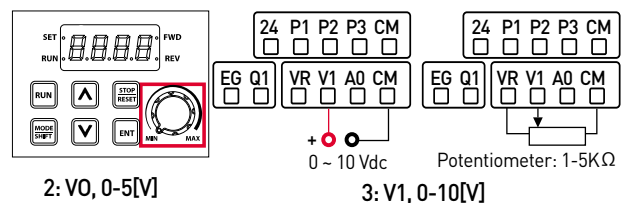
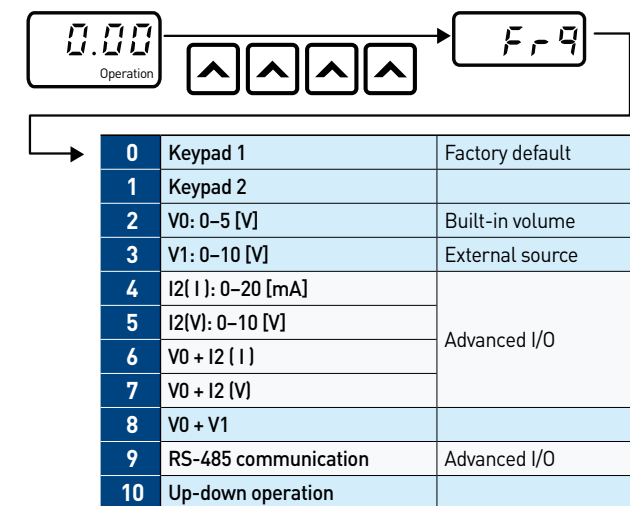

Multi-Step frequency

- This step shows how to set up and use the multi-step frequency of the drive.

| Group | Code | Name | Parameter Setting |
|-------|------|---------------------|---|
| In | 65 | P1 function setting | 5: Multi-step speed-low 6: Multi-step speed-middle 7: Multi-step speed-high |
| | 66 | P2 function setting | |
| | 67 | P3 function setting | |
| | 68* | P4 function setting | |
| | 69* | P5 function setting | |

* This is available only on Advanced I/O

- Example)

* Command source: Terminal

* I/O Type: Advanced I/O

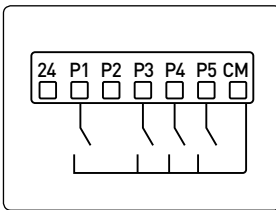

| Group | Code | Setting Value |
|-------|--------|--------------------|
| Op | drv | 1 (default: value) |
| | 65(P1) | 0 (default: value) |
| In | 67(P3) | 5 |
| | 68(P4) | 6 |
| | 69(P5) | 7 |

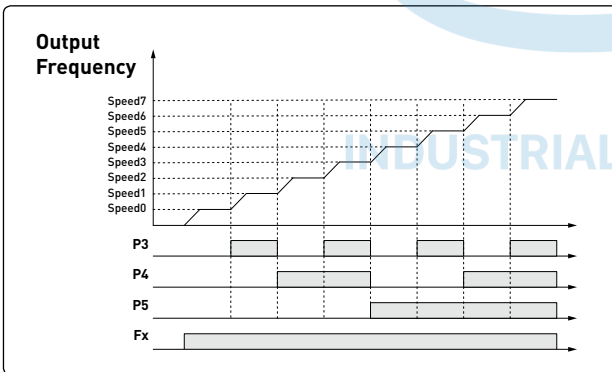

| Speed | P5 | P4 | P3 | Description |
|-------|----|----|----|--|
| 0 | - | - | - | Reference source set with the Frq in the operation group |
| 1 | - | - | ✓ | bA51_Multi-step frequency 1 |
| 2 | - | ✓ | - | bA52_Multi-step frequency 2 |
| 3 | - | ✓ | ✓ | bA53_Multi-step frequency 3 |
| 4 | ✓ | - | - | bA54_Multi-step frequency 4 |
| 5 | ✓ | - | ✓ | bA55_Multi-step frequency 5 |
| 6 | ✓ | ✓ | - | bA56_Multi-step frequency 6 |
| 7 | ✓ | ✓ | ✓ | bA57_Multi-step frequency 7 |

Auto restart

- This step shows how to set up and use an Auto Restart function of the drive.
- This feature is enabled only when a digital input terminal is configured as a command input device.

| Group | Code | Name | Setting Range |
|-------|------|------------------------------------|---------------|
| Pr | 09 | Auto restart count | 0~10 |
| | 10 | Auto restart delay time after trip | 0.0~60.0 sec |

※ If the reset signal is given manually via terminal or keypad, the restart count initializes to the set no. in Pr-09_Auto restart count.

※ When fault doesn't occur for 30 seconds, the remaining restart count recovers 1 by 1.

※ The Auto Restart function will not be activated if the drive stops due to the following fault trips:
- Low voltage, Emergency stop (Bx), Inverter overheating, or hardware diagnosis

- Example)

* Pr09=3, Pr10=5.0sec

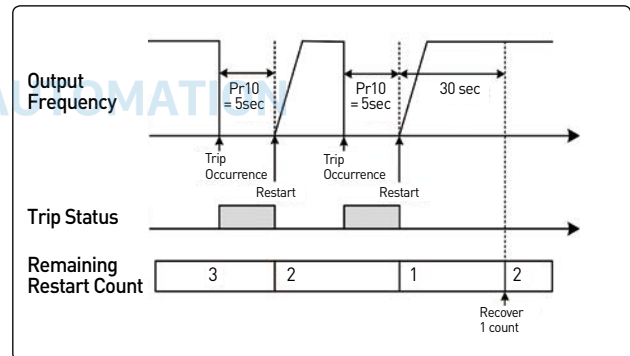

- Speed search - When a fault occurs, the motor is normally rotating at a free-run state. In order to operate the system without any additional fault due to rotating motor, speed search feature needs to be activated.

| Group | Code | Name | BIT | Function |
|-------|------|------------------------|-------------|-----------------------------------|
| Cn | 71 | Speed search selection | --1- (0010) | Initialization after a fault trip |

Basic parameter list



| Operation | |
|-------------------------|--------------------------|
| 0.00 | Command frequency |
| ACC | Acceleration time |
| dEC | Deceleration time |
| drv | Command source |
| Frq | Frequency Setting method |
| MkW | Motor selection |
| MrC | Rated motor current |
| MbF | Base frequency |
| FrM | Maximum frequency |
| Iov | Output voltage setting |
| Ftb | Forward boost |
| Rtb | Reverse boost |
| Cur | Output current |
| rPM | Motor RPM |
| dCL | Inverter DC voltage |
| vOL, POr, tOr, v1M, I2M | User select signal |
| nOn | Currently out of order |
| OGr | Open hidden groups |

※ Basic Parameters in Operation

- Only 18 parameters are shown in the first group to run the drive basically.
- The other groups are shown when "1" is set in the parameter OGr.



| |
|-----------------------|
| Drive |
| Basic |
| Advanced |
| Control |
| Input |
| Output |
| Communication |
| Application |
| Protection |
| 2 nd Motor |
| Configuration |

| Drive | |
|----------|---|
| 09 | Control mode |
| 11 | Jog frequency |
| 15 | Torque boost |
| 19 | Starting frequency |
| 20 | Select rotation direction |
| 26 | Automatic torque boost filter gain |
| 27 | Automatic torque boost motoring gain |
| 28 | Automatic torque boost regeneration gain |
| 81 | Select Monitor code |
| Basic | |
| 04 | Command source 2 |
| 05 | Frequency source 2 |
| 07 | V/F pattern |
| 08 | Unit of acc/dec time setting |
| 09 | Acc/dec frequency reference |
| 11 | Number of motor poles |
| 12 | Rated motor slip current |
| 14 | Motor no-load current |
| 15 | Motor efficiency |
| 50 ~ 56 | Multi-step frequency 1~ Multi-step frequency 7 |
| Advanced | |
| 01 | Acceleration pattern |
| 02 | Deceleration pattern |
| 03 | S-curve start point gradient |
| 04 | S-curve end point gradient |
| 08 | Stop mode selection |
| 09 | Forward and reverse run prevention |
| 10 | Starting with power on selection |
| 12 | DC braking time at startup |
| 13 | DC braking rate at startup |
| 14 | Output blocking time before DC braking |
| 15 | DC braking time |
| 16 | DC braking rate |
| 17 | DC braking frequency |
| 24 | Frequency lower and upper limit |
| 25 | Frequency lower limit |
| 26 | Frequency upper limit |
| 51 | Energy saving operation |
| 63 | Motor RPM display gain |
| 79 | DB operation voltage |
| Control | |
| 04 | Carrier frequency settings |
| 71 | Speed search selection |
| Input | |
| 08 | V1 Minimum input voltage |
| 09 | Frequency corresponding to V1 minimum input voltage |
| 10 | V1 Maximum input voltage |
| 11 | Frequency corresponding to V1 maximum input voltage |

| 65 | Multi-function input terminal P1 |
|-----------------------|---|
| 66 | Multi-function input terminal P2 |
| 67 | Multi-function input terminal P3 |
| 68 | Multi-function input terminal P4 |
| 69 | Multi-function input terminal P5 |
| 70 | PNP/NPN selection switch |
| 90 | Input terminal block status display |
| Output | |
| 01 | Analog output item setting |
| 02 | Analog output level adjustment |
| 31 | Multi-function relay setting |
| 32 | Multi-function output 2 feature selection |
| 41 | Output terminal block status display |
| Communication | |
| 01 | Inverter station ID |
| 02 | Communication protocol setting |
| 03 | Communication speed |
| 04 | Parity/stop bit setting |
| Application | |
| 01 | PID control setting |
| 02 | PID control unit selection |
| 18 | Amount of PID feedback |
| 19 | PID reference |
| 20 | PID reference setting |
| 21 | PID feedback setting |
| 05 | Output open-phase protection setting |
| 08 | Operation on reset after fault trip |
| 09 | Number of automatic restarts after fault trip |
| 10 | Automatic restart delay time after fault trip |
| 18 | Overload alarm level |
| 19 | Overload warning time |
| 20 | Overload warning selection |
| 21 | Overload fault level |
| 22 | Overload fault time |
| 50 | Stall prevention selection |
| 79 | Operation at fan fault |
| 91 ~ 95 | Fault history 1 ~ Fault history 5 |
| 2 nd Motor | |
| 04 | 2nd motor acceleration time |
| 05 | 2nd motor deceleration time |
| 07 | 2nd motor base frequency |
| 12 | 2nd motor rated current |
| Configuration | |
| 01 | Display after power on |
| 02 | I/O Type |
| 79 | Software version |
| 93 | Parameter initialization |
| 94 | Password registration |
| 95 | Parameter Lock |

Frequently asked questions

Question: The motor does not rotate and the output current is too high at start.

- Cause: the load is too high. It can be solved by using manual/auto torque boost and changing some parameters.

| | | |
|---|------------------------|---|
| 1 | Manual Torque Boost | Slightly increase the Forward or reverse boost in Ftb or rtb . If the torque boost level is too high, a trip may occurs such as IOL. |
| 2 | Auto Torque Boost(ATB) | Set dr15l to 1 to activate ATB. It is necessary to reduce manual boost values (ex. 0~2%) in Ftb or rtb , and then to adjust the values in dr26 , dr27 or dr28 . |
| 3 | Starting Frequency | Slightly increase the starting frequency in dr19 .(ex. 0.5 → 1.0 → 1.5 → 2.0Hz) |
| 4 | User V/F Pattern | When bA07 is set to 2 (User V/F), User V/F pattern can be set up according to the applications and motor characteristics. |

Question: The motor makes humming sound or loud noises.

- Answer: Slightly increase or decrease the carrier frequency in **Cn04**.

Question: When the drive is running, the Earth-leakage circuit breaker(ELCB) is activated.

- Cause: The ELCB will disconnect the power if leakage current flows to grounding during drive operation.
- Answer1: Connect the drive to grounding terminal.
- Answer2: Check if the ground resistance is less than 100 Ω for 200V class.
- Answer3: Check the capacity of ELCB and connect it to the drive according to the rated current of the drive.
- Answer4: Reduce the carrier frequency in **Cn04**.
- Answer5: Attempt to keep the cable distance from the drive to motor short as possible.

Question: How do I reset the drive back to factory default settings?

- Answer: Set **CF93** to 1 (All groups) and press the [ENT] key. **CF93** is displayed again when the initialization has been completed.

Question: How do I adjust the time it takes the motor to speed up or slow down?

- Answer: Adjust the acceleration time in **ACC** and deceleration time in **dEC**.

Question: How do I prevent the drive from tripping on an OV fault (overvoltage) while the motor is ramping down?

- Answer 1: Increase deceleration time in **dEC**.
- Answer 2: Activate stall prevention in **Pr50**. To enable it during deceleration, set **Pr50** to "-1-" as Bit 2..

Question: How do I prevent the drive from tripping on an OLT(overload) while the motor is ramping up and down?

- Answer: Verify motor rated current in **MrC** and motor overload parameter settings such as **Pr20** (Overload trip selection), **Pr21** (Overload trip level) and **Pr22** (Overload trip time).

Question: How do I run the motor above the nominal motor speed?

- Answer: Increase Maximum Frequency in **FrM**.

Question: Does the drive create harmonics? If so, are they a problem?

- Answer: All standard drives create 5th and 7th harmonic frequencies. Occasionally, and this depends on the applications there may be issues and harmonics can cause problems such as transformer heating or interference with other communication devices installed near the drive. To reduce interference, the installation of noise filters or line filters may be required. Additionally it may be helpful to adjust the carrier frequency to the minimum value in **Cn04**.

Troubleshoot faults

| Item | Type | Cause | Remedy |
|--|-------|--|---|
| OLt (Over Load) | Latch | The load is greater than the motor's rated capacity. | Replace the drive and motor with larger models. |
| | | The set value of Overload trip level in Pr21 is too low. | Increase the set value for of Overload trip level. |
| OcT (Over Current) | Latch | Acc/Dec times are too short compared to the load inertia (bA16). | Increase Acc/Dec times. |
| | | The drive load is greater than the rated capacity. | Replace the drive with a larger model. |
| | | The drive output is active while the motor is rotating. | Run the drive after the motor has stopped or Activate the speed search function (Cn71). |
| Ovt (Over Voltage) | Latch | The mechanical brake on the motor is activated too fast. | Check the mechanical brake. |
| | | Deceleration time is too short compared to the load inertia in bA16 . | Increase Deceleration time. |
| | | A generative load occurs at the drive output. | Use a braking option. |
| Lvt (Low Voltage) | Level | The input voltage is too high. | Check if the input voltage is above the specified value. |
| | | The input voltage is too low. | Check if the input voltage is below the specified value and adjust the drive input voltage value in bA19 . |
| | | The loads on the line power supply is greater than rated capacity such as welding machine, DOL motor, etc. | Increase the power capacity. |
| GFt (Ground Trip) | Latch | The magnetic contactor on the line power supply line is defective. | Replace the magnetic contactor. |
| | | Ground fault has occurred in the out circuit. | Check the wiring in the drive. |
| EtH (E-Thermal) | Latch | The motor insulation has been damaged. | Replace the motor. |
| | | The motor has overheated. | Decrease the load or reduce the motor operation. |
| | | The drive load is greater than the rated capacity. | Replace the drive with a large model. |
| OPO (Out Phase Open) | Latch | The drive has been running at low speed for a long time. | Replace the motor that has a cooling fan sourced by independent power. |
| | | The magnetic contactor in the output circuit is defective. | Check the magnetic contactor in the output circuit.. |
| IOL (Inverter OLT) | Latch | The wiring to the output is defective. | Check the wiring to the output. |
| | | The load is greater than the rated capacity of drive. | Replace the drive and motor with larger models. |
| Oht (Over Heat) | Latch | The torque boost level is too high. | Decrease the torque boost level. |
| | | There is a problem with the cooling system. | Check if there is a foreign object in the air inlet, outlet, or vent. |
| | | The cooling fan of the drive has been operated for a long time. | Replace the cooling fan. |
| ntC (NTC Open) | Latch | The ambient temperature is too high. | Keep the ambient temperature below 50°C. |
| | | The ambient temperature is too low. | Keep the ambient temperature above -10°C. |
| FAn (Fan Trip) | Latch | The internal temperature sensor has been damaged. | Contact your supplier or authorized service distributor of LSIS. |
| | | Foreign object is in the air vent of the drive. | Remove the foreign object from the air inlet or outlet. |
| EtA, EtB (External Trip A,B) | Latch | The lifespan of cooling fan is over. | Replace the cooling fan. |
| | | When the multi-function input terminal is set to EtA or EtB, the terminal is assigned as the its signal. | Adjust the parameters related to External trip. |
| COM (Communication Trip) | Latch | It occurs when communication between the Main DSP and the IO CPU is disconnected for more than 500ms | - |
| nbr | Latch | It occurs when the output current of the drive is below the value set in Ad41 while OU31 or OU32 is set to 19 [Brake signal]. | Adjust the parameters related to brake control. |

*Level : automatically terminates when the failure is solved. This is not saved in the failure history.

*Latch : terminates when the reset signals are input after the failure is solved.



■ Head Quarter

LS-ro 127(Hogye-dong) Dongan-gu, Anyang-si, Gyeonggi-Do, 14119, Korea Tel: 82-2-2034-4907 E-Mail: hjchoi@lsis.com